

CONF600HH  
CD600 CONFIGURATOR

User's Manual  
And  
Reference Guide

VERSION 1.02

## **Table of Contents**

<b>CONF600HH Introduction</b>	3
<b>CONF600HH Software Installation</b>	4
<b>Starting the Software</b>	5
<b>Programming Mode</b>	6
Example of Configuration	7
Configuring a Block in the Loop	9
Downloading a Configuration	10
<b>Operation Mode</b>	11
<b>Calibration Mode</b>	13
<b>Registering the CONF600HH</b>	15
<b>Software Updates</b>	16
<b>Calibrating the Palm handheld screen</b>	16

## **CONF600HH Introduction**

The **CONF600HH** is a Palm OS based software that runs in the Palm Operating System version 3.5 and later. The **CONF600HH Package** is comprised of three parts:

1. The communication interface, specifically, the **HPI311-M5-Plus**,
2. the Palm OS based handheld, and
3. the configuration software, specifically, the **CONF600HH**.

The **CONF600HH** software is compatible with most Palm handheld versions, this gives the user the flexibility to choose which handheld would be best suited for their purposes (for further information, refer to the *HPI311-M5-Plus Reference Guide*).

**HPI311-M5-Plus** - Compatible with Palm m125/130, m500/505/515, i705 (the Palm i705 is only available in the USA), Zire71, Tungsten W, Tungsten T and Tungsten T2.

## CONF600HH Software Installation

### NOTE

If you are unfamiliar with the Palm handheld and its associated terminology, first read the manual that came with your handheld to become familiar with its terminology and usage. Any Palm terminology used hereafter in this section will be denoted by *italic font*.

The **CONF600HH** setup program, CONF600HH.EXE, may be obtained from the Internet at <http://www.smarresearch.com/id47.htm> or from your local Smar distributor.

To Install/Upgrade the **CONF600HH** software:

1. Ensure the *cradle* is connected to your computer and the *Palm Desktop software* is installed.
2. Exit all open programs.
3. Start the setup program by double clicking on the **CONF600HH.exe** file.
4. When the **CONF600HH** Installer menu appears, click the Next button to begin the installation procedure and follow the on screen instructions.
5. Start the *Hotsync Manager*, if not already started.
6. Insert your handheld in its *cradle* and press the *HotSync* button. The **CONF600HH** application will automatically be installed into your Palm handheld.

Upon completion you should be able to see the **CONF600HH** icon in the Palm Handheld (Figure 1).

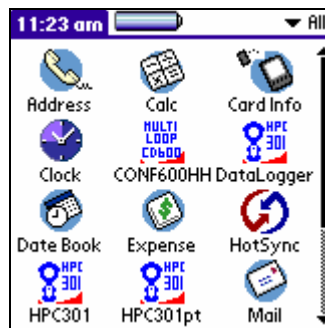

Figure 1

## Starting the Software

### NOTE

The CONF600HH together with the HPI311-M5-Plus is a replacement for the Psion, so it should be connected in the same way. The CD600 should be set to address 1. For more information, please refer to the **CD600** Operation Manual **Section 8**, Using The Hand-Held Terminal With a Controller In a Communication Network, for connection of the Configurator to the **CD600**.

To start the **CONF600HH** software:

1. Click the **CONF600HH** icon. The following screen will appear:

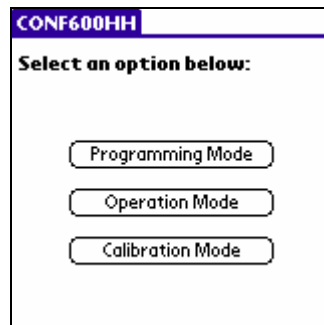

Figure 2

2. Click the desired button from one of the mode buttons available.

**Programming Mode:** Used for creating configurations which, when complete, can be downloaded into the **CD600** controllers or saved for later use.

**Operation Mode:** In this mode, the user can access any part of the configuration existing in the controller, which allows the user to monitor the output signal of any Function Block and the signals at the terminals of any "physical" input or output block. It is also possible to change the **Characterization** and **Adjustment Parameters** of these blocks. Monitoring, as well as eventual changes are performed "**on-line**".

**Calibration Mode:** This mode allows the user to calibrate the Analog Outputs (4 Voltage output and 4 Current Output) and Analog Inputs (8 Analog Inputs) of the CD600.

## Programming Mode

A configuration for a **CD600** controller may contain up to four control **LOOPs**. In addition to these four **LOOPs**, the configuration must contain an additional LOOP, called **Loop G**, containing the **TAG** (Identification) of the entire configuration and the blocks whose information can be shared by more than one of the control **LOOPs**.

Before starting to learn how to develop a configuration, it is necessary to understand the following concepts (Loop Configurations):

**Loop Configurations (Figure 3)**- The Loop Configurations screen is the starting point of the configuration to be created. There are three types:

**New** - There is no configuration to be used as a starting point. It is like starting a new drawing on a blank sheet of paper.

**Online** - The starting point is a configuration that is in the CD600 memory. This configuration will be transferred to the Palm, where it may be altered.

**Select Configuration** - The starting point is one of the configurations previously saved and stored in the Palm device. This configuration may be edited, connections changed, etc. This type is like copying a drawing and modifying it accordingly.

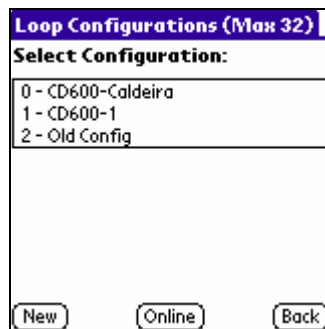

Figure 3

The next section shows a program development step-by-step. It is recommended that you follow this example.

## Example of Configuration

The following control strategy (Figure 4) shall be implemented in the **CD600**:

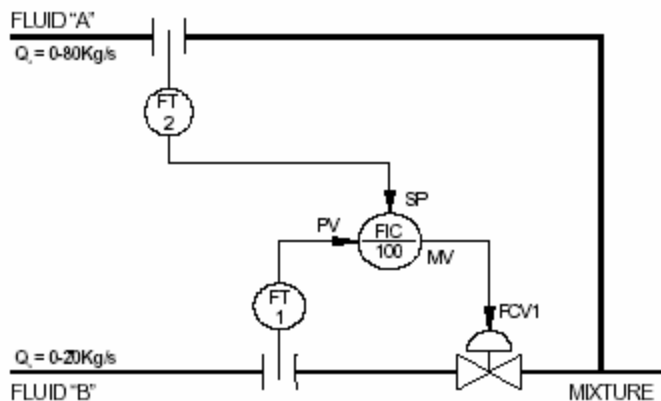
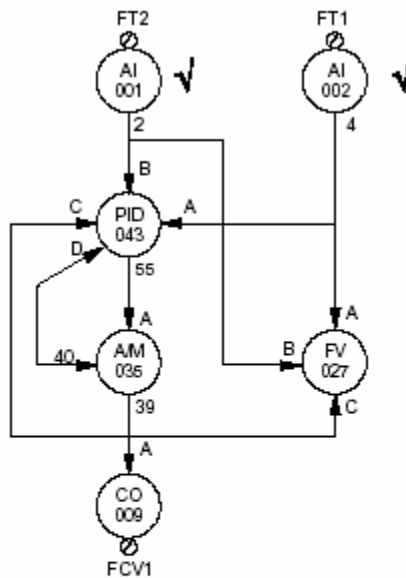

Figure 4- Desired Control Loop

Fluid B must be controlled in order to be equal to Fluid A. In section 4 of the **CD600** Operation Manual, function 12-ARTH, there is an example where the ratio  $Q_A/Q_B$  is adjustable. Before starting to work with the **CONF600HH**, it is recommended to manually draw the control configuration, using the library of blocks as a reference. The drawing should contain the block numbers and the terminal numbers as shown in Figure 5. The connections C and D of block 043 are explained in the block description. This is not important now, lets see how the program is developed and downloaded to the controller first.



LIST OF BLOCKS		LOOP G
LOOP1		TAG: FIC 100
TAG:	FLOW	
1:	BLK 001	
2:	BLK 002	
3:	BLK 043	
4:	BLK 035	
5:	BLK 009	
6:	BLK 027	

Figure 5 - Configuration of a Control Loop

The following sequence should be used to configure the controller.

1. From the **Loop Configuration** screen, *click* the **New** button.
2. Type the name of the new configuration, for example FIC (Figure 6).
3. *Click* the **OK** button.

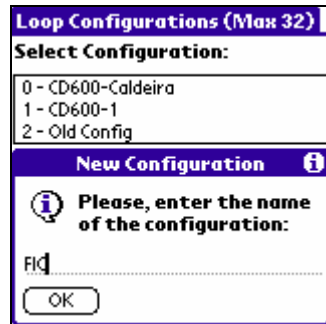

Figure 6

4. Select this name (FIC) from the list. You will now be in the main programming screen (Figure 7).

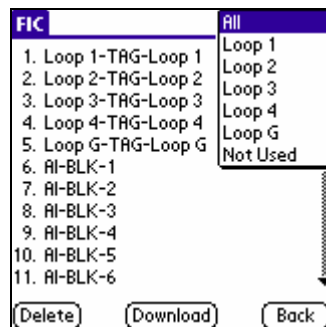

Figure 7

5. Select the Loop 1 and Loop G to change the **Tag** value (Figure 8).
6. **Click** the **Done** button to return to main screen.

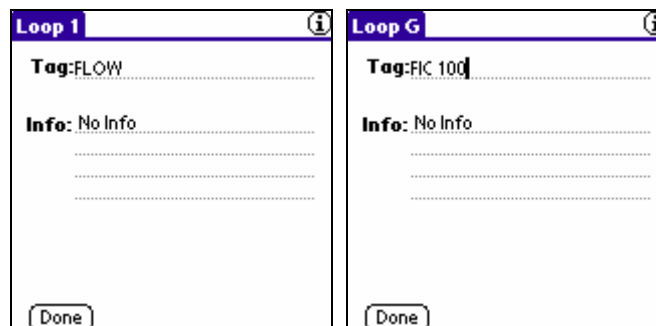

Figure 8

7. Now select block by block and configure as desired. (See *Configuring a Block into the Loop.*)
8. After the entire configuration is complete, you have two options, download (see *Download a Configuration*) to the Controller or save for later use (*click* the **Back** button).

## Configuring a Block into the Loop

- From the main programming screen (Figure 9A), select the desired block, for example Block 9 (Figure 9B).

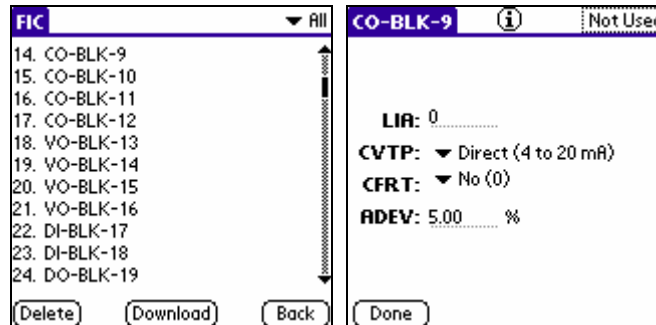

Figure 9A

Figure 9B

- Select which Loop this block should be in. (Figure 10)

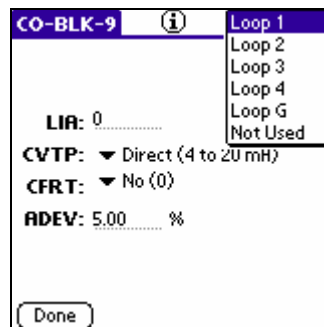

Figure 10

- Configure the parameters as desired, if you need more information about the block, please click the **i** icon at the top of this screen (Figure 11).

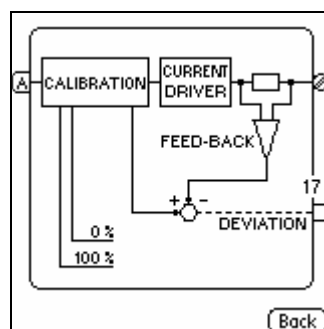

Figure 11

- Repeat the steps above for all desired blocks contained in the configuration.

## Downloading a Configuration

After the configuration is complete the next step is to download the configuration to the **CD600**.

1. From the main programming screen (Figure 12A), *click* the **Download** button.

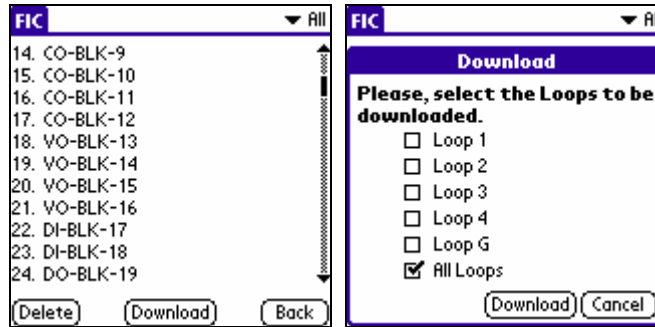

Figure 12A

Figure 12B

2. Select the desired Loops to download (Figure 12B).
3. *Click* the **Download** button.

### NOTE

It is strongly recommended to download All Loops. The option to select individual loops for download is recommended only for advanced users.

## Operation Mode

The Operation Mode enables the user to change block Characterization and Adjustment parameters, monitor block outputs, and monitor analog and digital inputs and outputs (Terminals).

When you *click* the **Operation Mode** button (Figure 13A), the configuration that is in the **CD600** memory will be transferred to the Palm, where it can be viewed (Figure 13B).

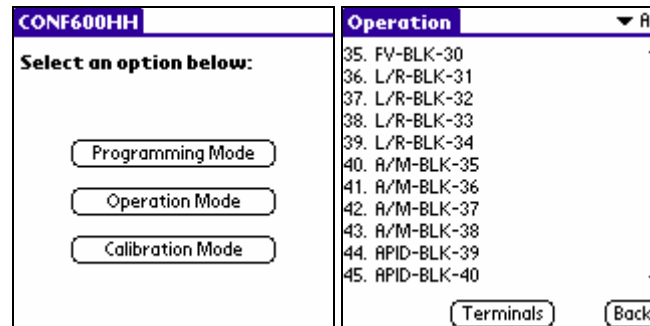

Figure 13A

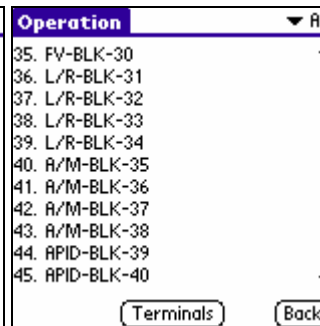

Figure 13B

To change block Characterization and Adjustment parameters:

1. *Click* the desired Block (i.e. Blk 35 - Figure 14).
2. Change the desired parameters.
3. *Click* the **Send** button.

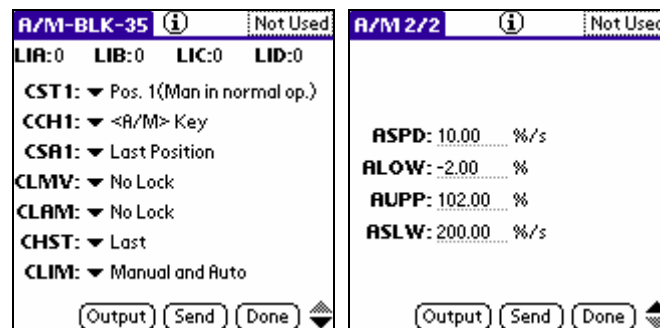

Figure 14

To monitor block outputs (Figure 15):

1. *Click* the desired Block (e.a. Blk 35 - Figure 14).
2. *Click* the **Output** button.

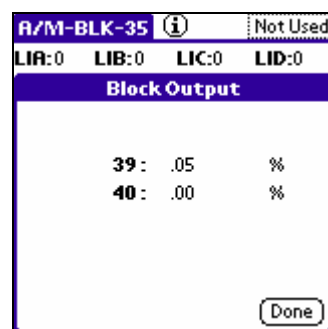

Figure 15

To monitor analog and digital inputs and outputs (Figure 16):

1. Click the **Terminals** button.

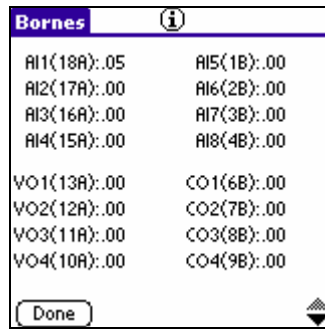

Figure 16

## Calibration Mode

NOTE
Before proceeding please read <b>Section 7</b> of the <b>CD600</b> Operation & Maintenance Instructions Manual.

In Calibration Mode, the user is able to calibrate the Analog Inputs (Manually or Automatically), the Current Outputs, and the Voltage Outputs (Figure 17).

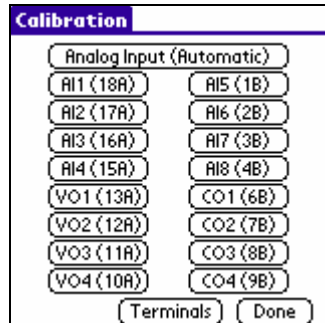

Figure 17

To calibrate the Analog Inputs (Manually), Current Outputs, or Voltage Outputs:

1. Click the desired **AI**, **VO**, or **CO**.
2. Enter the correct reading for each point (Figure 18).
3. Click the **Send** button.

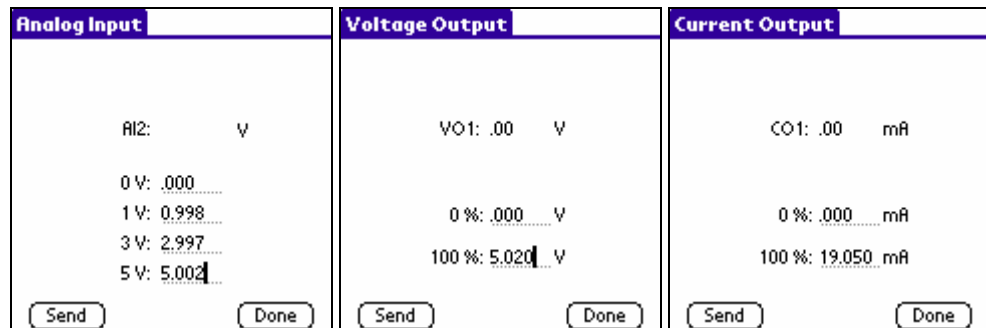

Figure 18

To Calibrate the Analog Inputs (Automatically):

1. Click the **Analog Input (Automatic)** button.
2. Select the desired Analog Inputs (Figure 19).
3. Click the **Next** button.
4. Apply the desired Voltage/Current and then *click* the corresponding button (Figure 20).
5. Repeat step 4 for each point.

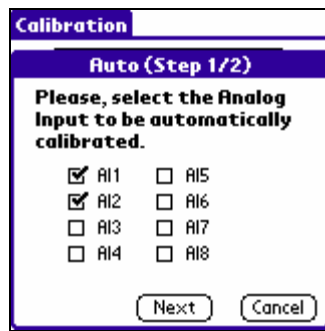

Figure 19

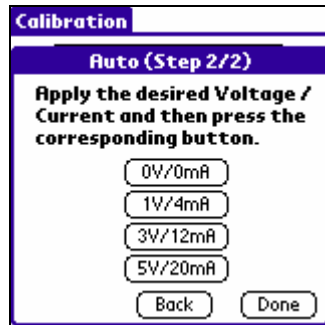

Figure 20

## Registering the CONF600HH

To register the **CONF600HH**, please send the information below to Smar Research via fax or e-mail. The \* refers to required information.

**To:** Smar Research Corporation  
**E-mail:** TechSupport@SmarResearch.com  
**Fax:** +1 631 737 3892

### ***User's Information***

User Name:  
Title:  
Company Name:  
Address:  
City:                      State:                      Zip Code:  
Phone:                      Fax:  
\*E-mail:

### ***HPI311-M5-Plus Information***

\*HPI311-M5-Plus serial number:

NOTE
Registered users receive technical support, early notification of product upgrades, and new product announcements.

## **Software updates**

Software updates are available at <http://www.smarresearch.com/id47.htm>.

## **Calibrating the Palm handheld screen**

Sometimes when you try to *click* the buttons or icons on your Palm screen, the handheld will activate the wrong feature. If this happens, it usually means that the Palm handheld screen needs to be calibrated. Please refer to the Frequently Asked Questions (tapping and writing problems) section of your Palm manual for calibration instructions.