

Fieldbus Passive Repeater RP302 Datasheet

HART®
Fieldbus
Profibus
Intrinsic Safety
Configuration Tools
Semiconductors
Training
Custom Design



Features

- 1500 VAC Isolation between networks
- Very Low DC leakage at repeater inputs
- Each unit can extend the Fieldbus network length up to 1900 meters
- Includes selectable bus terminators on both network sides
- 8 bit preamble can use 4 repeaters; 16 bit preamble can use 8 repeaters in series
- Accommodate conductors up to 2.5mm² (12 AWG)
- Fast snap-on DIN mounting rail assembly
- Conforms to IEC 1158-2, 31.25 Kbit/s standard for Foundation Fieldbus and PROFIBUS

General Description

As cable lengths increase control signals deteriorate and can become unreadable by devices on the network. Signal repeaters can be used to avoid deterioration in large networks or over long network cable runs.

The RP302 takes an incoming signal from one network segment, "cleans" it for errors, and re-transmits the signal at full strength to another network segment, maintaining signal quality and message integrity throughout all network segments. The RP302 performs this function in a bi-directional fashion to support Fieldbus Networks. It is fully compliant with the IEC1158-2/ISA-S50.02 physical layer definition and specifications for Foundation Fieldbus and PROFIBUS.

An H1 bus topology Fieldbus network with DC power can support a network segment cable length of up to 1900 meters. Up to 4 repeaters may be used in series, providing for the total cable length of any particular network trunk or spur to be increased up to 5 times the cable length of one segment. This allows for a Fieldbus device to be located up to 9.5 Km (5.9 miles) away from a control room.

Note: *Distances may vary according to the application and field device characteristics. Consult the appropriate specifications from device manufacturers when designing a Fieldbus network.*

Technical Characteristics

Power

- *Power Supply (Input):
Voltage: 24Vdc \pm 5%
Current (max.): 30mA at 24 Vdc
- *Internal Dissipation:
0.72W max. at 24V input

Limitations

- *Cable length*:
1900 meters per Fieldbus network segment
- *Number of devices*:
2 - 12 per network segment
- *Number of Repeaters**:
(per H1 Fieldbus network trunk or spur)
8 bit preamble: 4
16 bit preamble: 8 repeaters
- *Digital Signal Transmission*:
31.25 kbit/second.
- *Fuse:

Power Supply: 250 mA
Fieldbus Inputs: 100 mA

- *Terminals : Conductors up to 4mm²
(12AWG)
- *Isolation:
250 Vac between input, output, and power supply terminals.
Factory tested to 1500V rms minimum

Physical

- *Ambient Temperature Range:
-20° to +60° C (continuous operation)
-40° to +80° C (storage/off line)
- *Humidity:
5% to 95% relative humidity
- *Mounting:
Fast snap-on to DIN mounting rail
Corner screw mounts (flush)

* Complies with the IEC61158-2 Physical Layer definition for Fieldbus.

** Applies only to networks wired in series.

Network Applications

Series Topology

A serial architecture permits a series of up to 4 repeaters along a single Fieldbus network trunk or segment, each extending the network up to an additional

1900 meters. The example below shows the application of two SmarResearch RP302 Fieldbus Repeaters in a series topology.

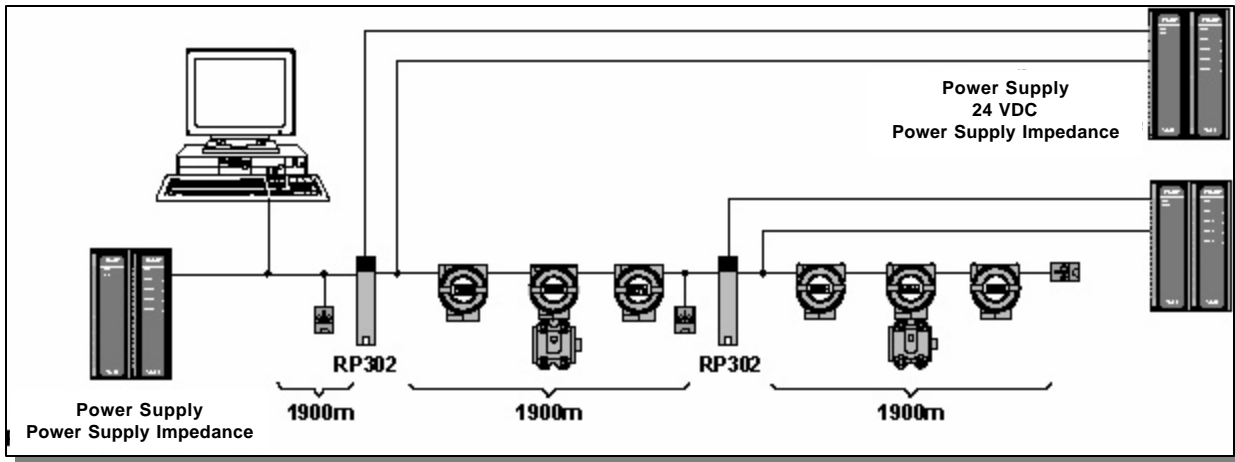

Parallel Topology

A parallel architecture permits almost an unlimited number of repeaters in parallel along the main trunk within the limits of the IEC1158-2/ISA-S50.02

physical layer definition. The example below uses four SmarResearch RP302 Fieldbus Repeaters to extend the cable length of each network spur up to 1900 meters.

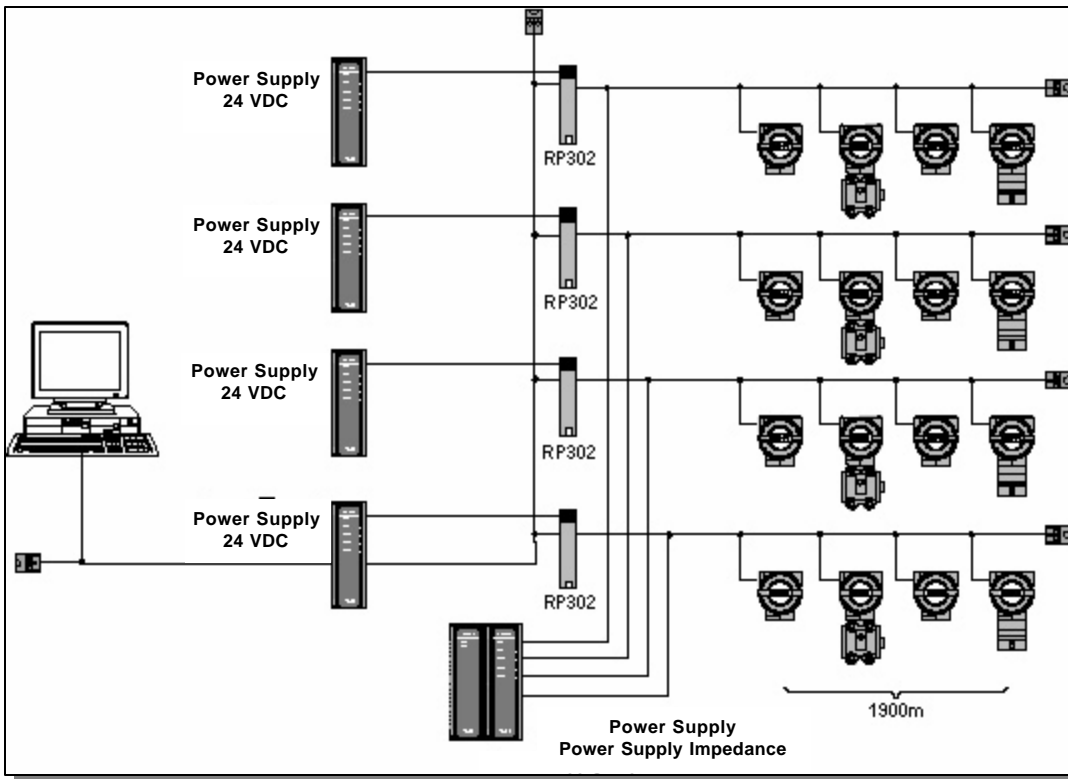

Mixed Topology

A mixed architecture combines series and parallel topologies for a virtually unlimited number of network configurations. The diagram below shows three SmarResearch RP302s in parallel originating from the main trunk with additional RP302s being used in

series to extend the cable lengths of individual network spurs. The Host is connected in parallel to each RP302 on the main trunk. Although only a two RP302s are shown in series in the example, up to 4 can be used on each network spur, extending the cable length up to 9.5 Km from the main trunk.

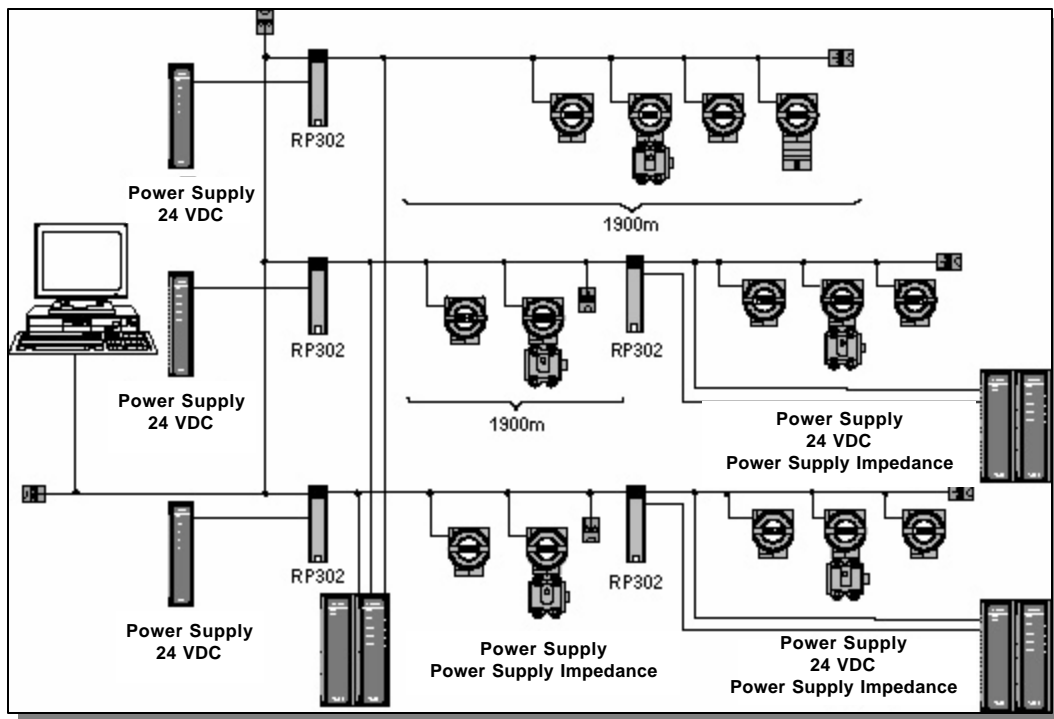

Note:

Distances and network configuration specifications may vary according to the application and field device characteristics. The network representations shown are simple examples to illustrate the types of configurations that can be implemented. Consult the appropriate device specifications when designing a Fieldbus network application.

To preserve the isolation provided by the SmarResearch RP302 Fieldbus Repeater each network segment requires its own power supply and power supply impedance to power the field devices connected to that particular segment.

Physical Attributes

Installation

SmarResearch RP302 Fieldbus Repeater, should always be installed by competent technical personnel. Contact SmarResearch or your local representative for further information.

Before proceeding to install and wire the RP302. Please, read and thoroughly understand these instructions.

Location

The device itself must be situated in a non-hazardous area where an explosive atmosphere will not exist at any time during repeater or network operation. If it is necessary to install in a hazardous area then it must be mounted

in a suitable approved explosion-proof enclosure with approved explosion-proof seals.

Mounting

The RP302 mounts easily by fast snap-on to a standard DIN mounting rail. It can also be panel mounted using provided corner mounting holes that accept two M4 or M5 (#6 or #10) screws. These mounting holes are molded into two corners of the housing shell base and do not increase the height or width of the enclosure, permitting multiple enclosures to be installed adjacent to each other with no clearance.

Functional Diagram

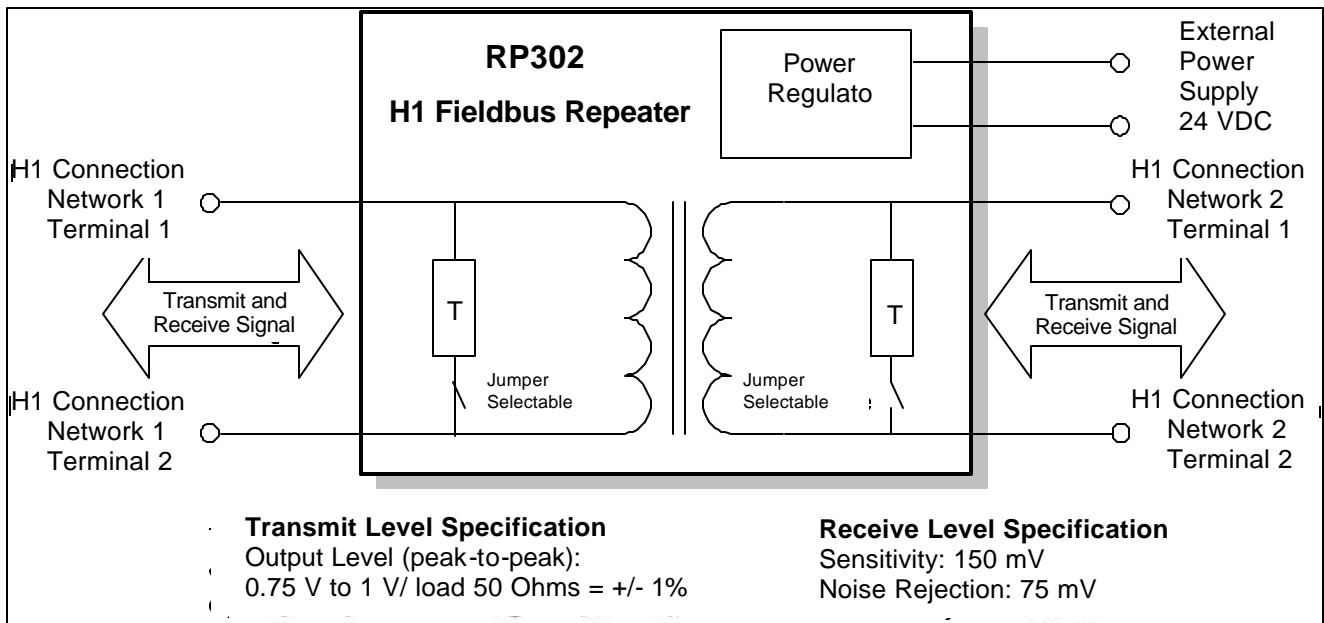

Note: Internal terminators can be disabled by removing the shorting jumpers. Units are shipped with jumpers in place.

Terminal Blocks

Connection	Description
1	Fieldbus I/O - Network 0
2	Fieldbus I/O - Network 0
3	24 VDC - Power Supply (+)
4	24 VDC - Power Supply (-)
5	Fieldbus I/O- Network 1
6	Fieldbus I/O- Network 1
7	Do Not Use
8	Do Not Use

1	2	3	4
H1 I/O (0)		+	-
24 VDC			
RP302			
H1 FIELD BUS REPEATER			
H1 I/O (1)			
5	6	7	8

Installation Guideline

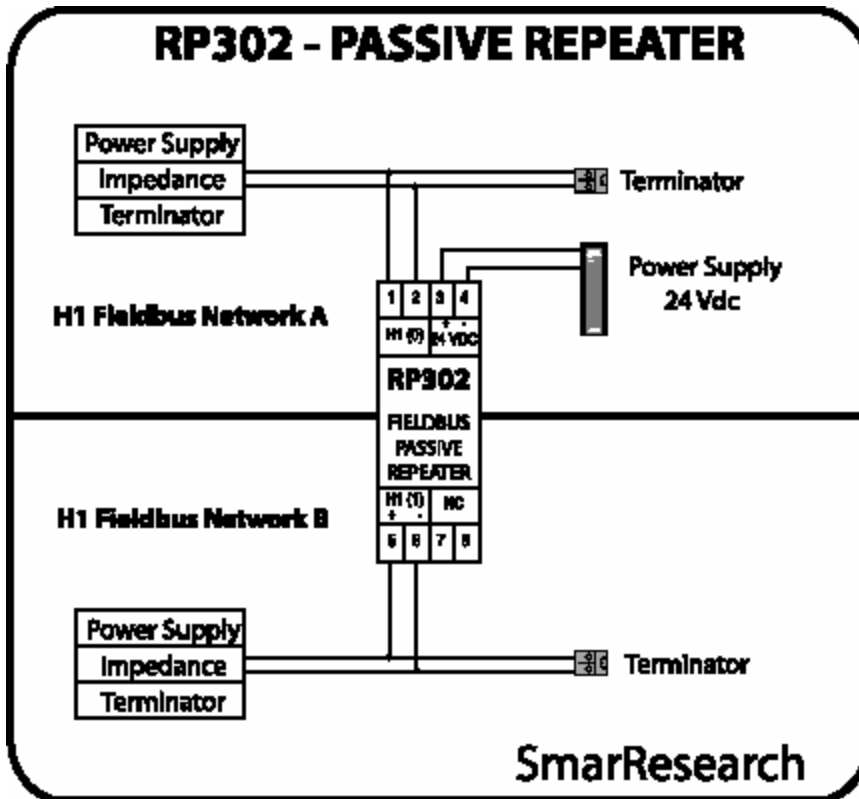

Note: The head cover on the enclosure should be orientated so that the bottom of the text on the head cover coincides with the side of the enclosure with the red latch at the bottom.

The internal terminators can be disabled or enabled using the shorting jumpers. The unit is shipped with the shorting jumpers in place.

Mechanical Dimensions

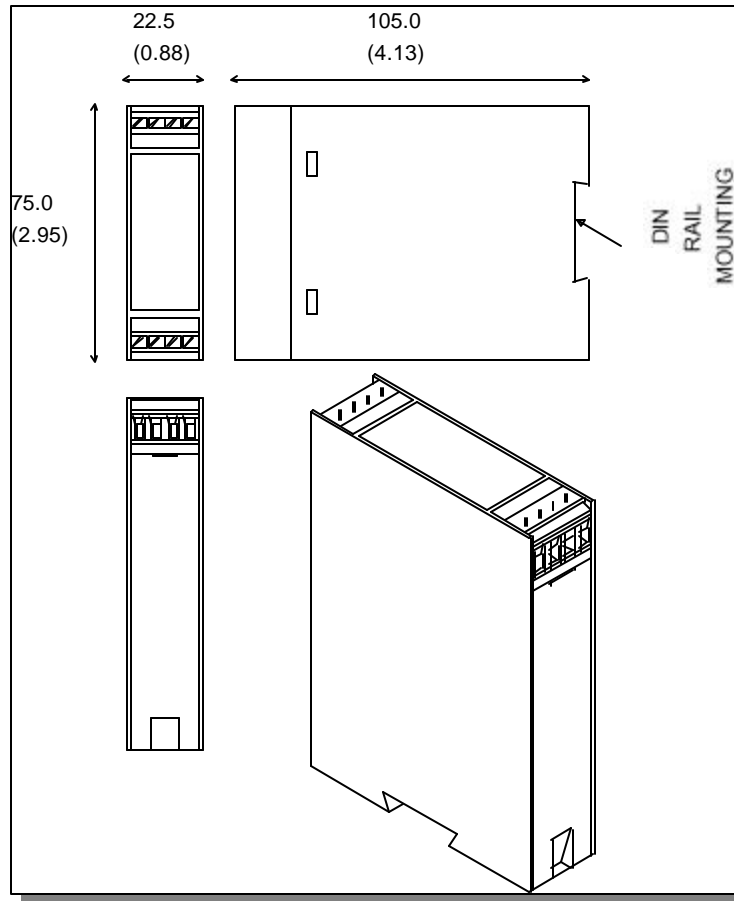

RP302 Physical Attributes

Smar Research reserves the right to make changes to design and functionality of any product without notice. Smar Research does not assume any liability arising out of the application or use of any product. Smar Research , Technology Source, and the SRC logo are registered trademarks of Smar Research Corporation. The HART, Fieldbus, and Profibus Foundation logos are trademarks of their respective owners.

Smar Research Corporation
4250 Veterans Memorial Highway
Holbrook, NY USA 11741
Tel: 631.737.3111 Fax: 631.737.3892
techinfo@SmarResearch.com
www.SmarResearch.com



©Smar Research Corporation

